



A1400 AIR

Automation for sliding doors

FAAC
Simply automatic.

A1400 AIR

The right solution
for all your needs

SOLUTIONS WITH COVER H 100 mm

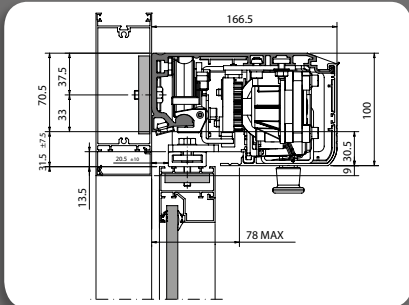

With commercial profiles

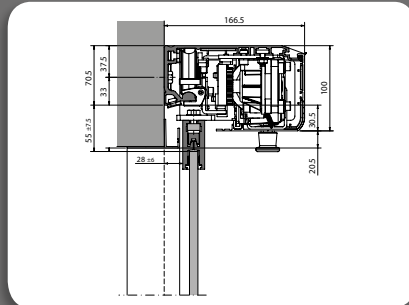

With FAAC gripper for polished edge glass

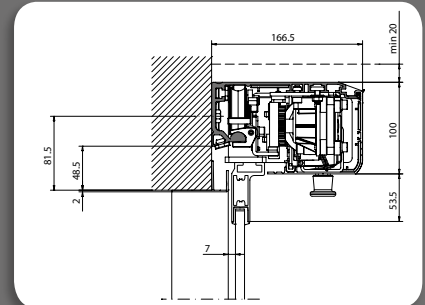

With FAAC TK20 reduced section profiles

SOLUTIONS WITH COVER H 140 mm

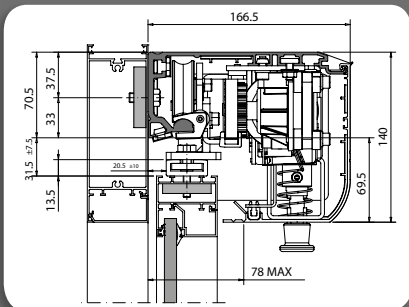

With commercial profiles

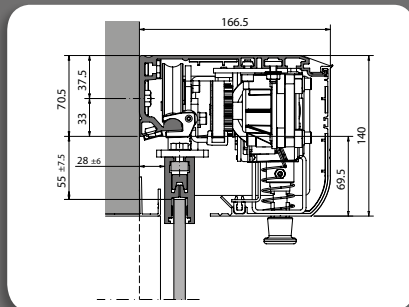

With FAAC gripper for polished edge glass

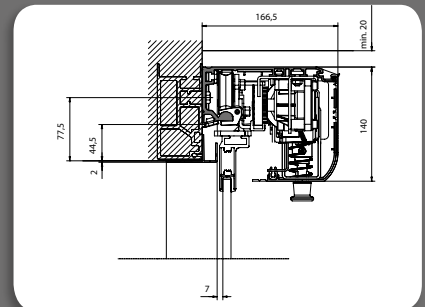

With FAAC TK20 reduced section profiles

SOLUTIONS WITH SPECIAL VERSIONS H 100 MM AND H 140 MM

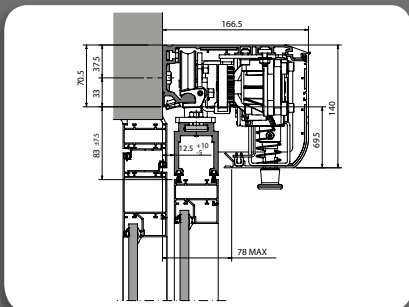

With profiles for APN anti-panic
breakout systems

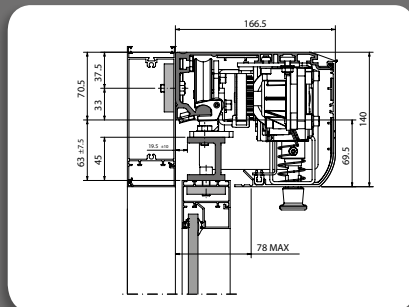

With spacers

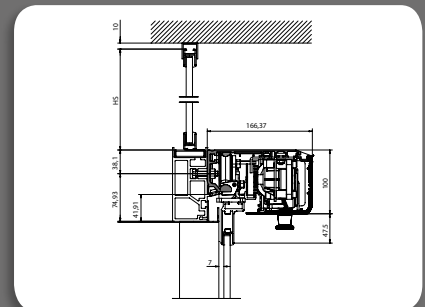

With self-supporting profile, transom and FAAC
TK20 reduced section leaf profiles

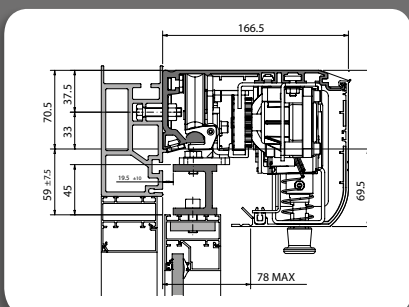

With self-supporting profile and spacers

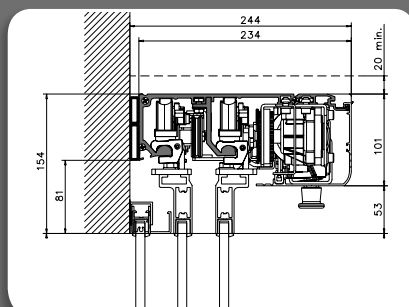

Telescopic version with installation
on masonry

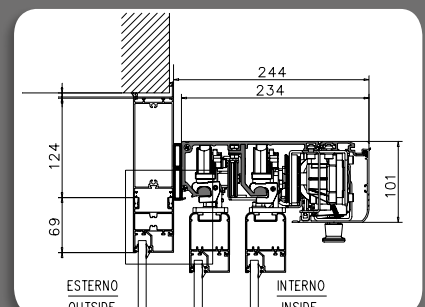

Telescopic version with installation
on head section

The future is here

The FAAC A1400 AIR SERIES automations are designed to automate entrances in compliance with European standard EN 16005; in fact, they are able to meet the most stringent safety requirements of EN 13489-1 PI "c".

Its innovative "Energy Saving" device enables it to identify the direction of transit and optimises opening / closing times perfectly to avoid unnecessary air dispersion, even in the event of cross traffic.



The A1400 AIR automation is customisable and can be assembled to meet the architectural and technical requirements of the customer. Its two types of cover, the exclusive leaf attachment systems and the various leaf profiles that can be used make it possible to achieve the best technical and architectural solution.

Designed to operate at best in any condition and in any environment, it is the optimum solution for technicians who wish to save assembly time, by rationalising inventories for the final customer who will have full access to a product that is personalised, ecological, reliable, safe, technologically advanced and above all, that will pay for itself over time.



MADE IN ITALY

TECHNICAL CHARACTERISTICS

Power supply	220-240 V~ - 50/60 Hz
Max power	140 W
Frequency of use	100%
Max leaf thickness	65 mm
Electric motor	36V motor  with encoder
Max. accessories load	1A - 24V 
Drive type	Electro-conductive toothed belt
Opening speed adjustment	10 - 75 cm/s (1 leaf), 20 - 150 cm/s (2 leaves)
Closing speed adjustment	10 - 75 cm/s (1 leaf), 20 - 150 cm/s (2 leaves)
Partial opening adjustment	5% - 95% of total opening
Pause time	0 - 30 s or Energy Saving function
Night pause time	0 - 240 s
Encoder	Standard
Protection sensor monitoring (EN16005)	Standard (may be bypassed)
Low Energy movement (EN16005)	Standard (may be bypassed)
Operating temperature	-20°C to +55°C
Protection rating	IP 23 (for indoor use only)
Compliance with standards	EN 16005; EN 13489-1 PI "c"; EN 13489-2; EN 60335-1; EN 60335-2; EN ISO 12100; EN 61000-6-2; EN 61000-6-3





MOTOR WITH ELECTRIC LOCK

1



TELESCOPIC VERSION

3



SLIDING CARRIAGES

Carriages with sliding wheels made of synthetic material mounted on bearings and reinforced for double motor versions. Sliding on an anodised aluminium track integrated into the profile.

4

ACCESSORIES

Clamping profiles for glass leaves.



Anti-panic breakout system.

Not available for the telescopic version.

Compatible with

FAAC TK20 and **TK50** series profiles.

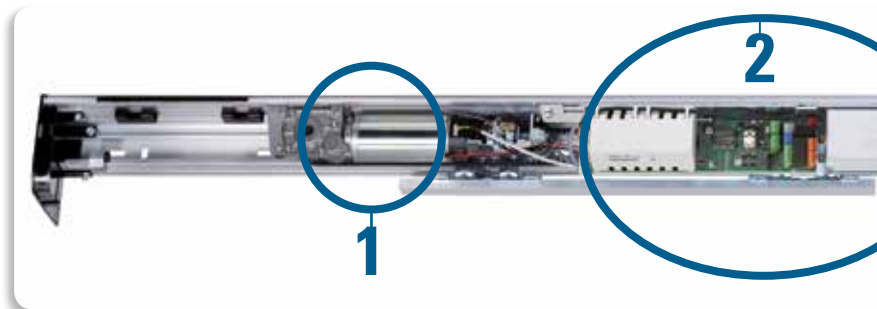

1

2



SLOT FOR FAST MECHANICAL INSTALLATION

5

AUTOMATIC ADJUSTMENTS

Determination of opening and closing positions. Selection of ideal speed, acceleration and deceleration. Protection sensor monitoring. Anti-crushing safety device in compliance with EN 16005.



CONTROL UNIT WITH SWITCHING POWER SUPPLY

2



SECOND MOTOR KIT AVAILABLE AS AN ACCESSORY

6

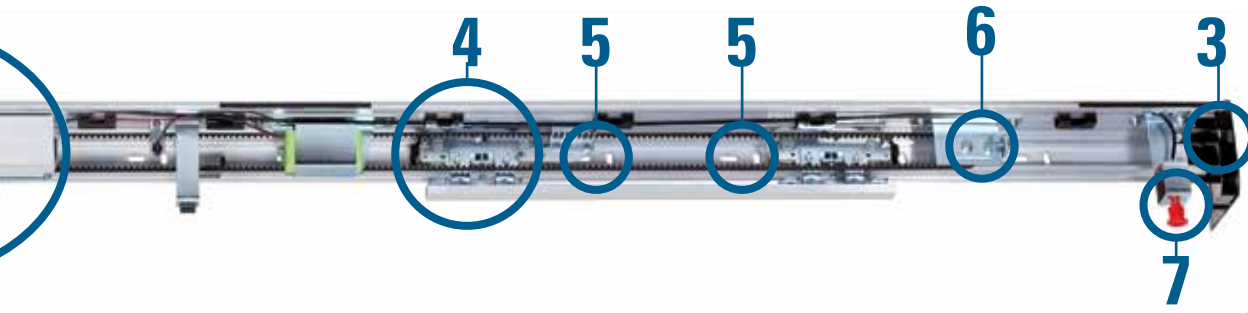

MANUAL RELEASE WITH KNOB

7

USE

MODEL	LEAF	PASSAGE OPENING (mm)	MAX. LEAF WEIGHT (mm)	SELF-SUPPORTING BEAM
A1400 AIR 1	Single	700-3000	200 Kg	No
A1400 AIR 2	Double	800-3000	120+120 Kg	No
A1400 AIR A 1	Single	700-3000	200 Kg	Yes
A1400 AIR A 2	Double	800-3000	120+120 Kg	Yes
A1400 AIR DM 1	Single	800-3000	250 Kg	No
A1400 AIR DM 2	Double	900-3000	180+180 Kg	No
A1400 AIR T 2	Single telescopic	1100-3000	110+110 Kg	No
A1400 AIR T 4	Double telescopic	1400-4000	60+60+60+60 Kg	No
A1400 AIR A T 2	Single telescopic	1100-3000	110+110 Kg	Yes
A1400 AIR A T 4	Double telescopic	1400-4000	60+60+60+60 Kg	Yes

A1400 AIR



SDK EVO PROGRAMMING AND FUNCTIONS KEYPAD

Supplied as an accessory, it comes with a large graphics display that allows full access to all the door parameters via the four buttons that allow the user to navigate through the menus

MAIN FUNCTIONS

MODEL	SDK EVO
Operating functions	Manual - Night - Automatic One-directional - Partial One-directional Partial opening - Open - Reset and setup
Operating functions selection	Via buttons with indication of the selected function on the display. Option of locking the keypad via a jumper or a combination of keys.
Main programming functions	User and installer password entry - Opening and closing speed adjustment- Opening and closing force adjustment - Anti-crushing adjustment - Pause time adjustment - Energy Saving Enable - Diagnostics display management - Weekly calendar management - Battery kit and motor block management - I/O programming - Maintenance cycles notification - Display of number of cycles performed
Programming	Full with PROGRAMMER password and basic with USER code.



LK EVO FUNCTIONS SELECTOR

Supplied as an accessory, it allows the main functions of the automation to be accessed and indicates if they are enabled by means of LEDs.

MAIN FUNCTIONS

MODEL	LK EVO
Operating functions	Manual, Automatic, Night, Open, One-directional, Partial opening
Operating functions selection	Via buttons with LED indication of the selected function
Selectable functions	Setup, Reset, Keyboard inhibit (also via jumper)
Diagnostics	Via combinations of flashing LEDs

ACCESSORIES

XV1 DUAL TECHNOLOGY RADAR
"MOVEMENT AND PRESENCE"



XDT1 DUAL TECHNOLOGY, MICROWAVE
AND ACTIVE INFRARED THRESHOLD SAFETY SENSOR
"MOVEMENT AND PRESENCE"



XMS TOUCH BUTTON



ELBOW SWITCH



EMERGENCY BATTERY WITH
CHARGE
CONTROL
BOARD



MONOSTABLE XM LOCK
MOTOR BLOCK



BISTABLE XB LOCK MOTOR
BLOCK
W/KNOB



MOTOR BLOCK AND LEAF
POSITION
MONITORING



XTRB TAG READER



A1400 AIR QUALITY COMPLIANCE

Head for 2,000,000 cycles (opening and closing) according to DIN 18650-1.
Compliant with the Low Voltage Directive (2014/35/EU), Electromagnetic Compatibility Directive (2014/30/EU), Machinery Directive (2006/42/EC) and the RoHS Directive 2011/65/EU

HEADQUARTERS

ITALY

FAAC S.p.A. - Soc. Unipersonale
Via Calari 10 - 40069 Zola Predosa (BO)
Tel. +39 051 61724 - Fax +39 051 758518
it.info@faacgroup.com - www.faacgroup.com

SUBSIDIARIES

ASIA - PACIFIC

FAAC MALAYSIA
MAGNETIC CONTROL SYSTEMS SDN BHD
Selangor, Malaysia
tel. +60 3 5123 0033
www.faac.biz

AUSTRALIA

FAAC AUSTRALIA PTY LTD
Homebush – Sydney, Australia
tel. +61 2 87565644
www.faac.com.au

AUSTRIA

FAAC GMBH
Salzburg, Austria
tel. +43 662 85333950
www.faac.at

FAAC BV - TUBULAR MOTORS
Doetinchem, The Netherlands
tel. +49 30 5679 6645
faacbv.info@faacgroup.com
www.faac-tubularmotors.com

BENELUX

FAAC BENELUX NV/SA
Jabbeke, Belgium
tel. +32 50 320202
info@faacbenelux.com
www.faacbenelux.com

FAAC BV
Doetinchem, The Netherlands
tel. +31 314 369911
faacbv.info@faacgroup.com
www.faacbv.com

BRAZIL

INDÚSTRIAS ROSSI ELETROMECAÂNICA SA
Brasília DF, Brazil
tel. +55 61 33998787
www.rossiportoes.com.br

CHINA

FAAC SHANGHAI
Shanghai, China
tel. +86 21 68182970
www.faacgroup.cn

FRANCE

FAAC FRANCE
Saint Priest - Lyon, France
tel. +33 4 72213020
www.faac.fr

FAAC FRANCE - AGENCE PARIS
Massy - Paris, France
tel. +33 4 72213020
www.faac.fr

FAAC FRANCE - DEPARTEMENT VOILETS
Saint Denis de Pile - Bordeaux, France
tel. +33 5 57551890
www.faac.fr

GERMANY

FAAC GMBH
Freilassing, Germany
tel. +49 8654 49810
www.faac.de

FAAC BV - TUBULAR MOTORS
Doetinchem, The Netherlands
tel. +49 30 5679 6645
faacbv.info@faacgroup.com
www.faac-tubularmotors.com

INDIA

FAAC INDIA
MAGNETIC AUTOCONTROL PVT LTD.
Chennai – India
Tel. +91 44 421 23297
info@magnetic-india.com
www.faac.biz

IRELAND

NATIONAL AUTOMATION LTD
Co. Roscommon, Ireland
tel. +353 71 9663893
www.nal.ie

MIDDLE EAST

FAAC MIDDLE EAST FZE
Dubai Silicon Oasis Operation Center - Dubai, UAE
tel. + 971 4 3724190
www.faac.ae

POLAND

FAAC POLSKA SP.ZO.O
Warszawa, Poland
tel. +48 22 8141422
fax +48 22 8142024
www.faac.pl

RUSSIA

FAAC RUSSIA
Moscow, Russia
tel. +7 (495) 646 24 29
www.faac.ru

SCANDINAVIA

FAAC NORDIC AB
Perstorp, Sweden
tel. +46 435 779500
www.faac.se

SOUTH AFRICA

CENTURION SYSTEMS PTY LTD
2162 Johannesburg
tel. +27 11 699 2400
www.centsys.co.za

SPAIN

CLEM, S.A.U.
San Sebastián de los Reyes - Madrid, Spain
tel. +34 91 3581110
www.faac.es

SWITZERLAND

FAAC AG
Altdorf, Switzerland
tel. +41 41 8713440
www.faac.ch

TURKEY

FAAC OTOMATİK GEÇİŞ SİSTEMLERİ
SAN. VE TİC. LTD. SİRKETİ
İstanbul, Turkey
tel. +90 (0)212 - 3431311
www.faac.com.tr

UNITED KINGDOM

FAAC UK LTD.
Basingstoke Hampshire, UK
tel. +44 1256 318100
www.faac.co.uk

U.S.A.

FAAC INTERNATIONAL INC
Rockledge, FL - U.S.A.
tel. +1 866 925 3222
www.faacusa.com

FAAC INTERNATIONAL INC
Fullerton, California - U.S.A.
tel. +1 714 446 9800
www.faacusa.com

FAAC
Simply automatic.

FAAC S.p.A. - Soc. Unipersonale
Via Calari 10 - 40069 Zola Predosa (BO)
Tel. +39 051 61724 - Fax +39 051 758518
it.info@faacgroup.com - www.faac.it